

Turn-key Plants for the Plastics Processing Industry
Innovative Technology – Economic Handling of Bulk Solids





A century of experience gained through your tasks

The industry sector of the Zeppelin Group is among the leading manufacturers of plants for storing, conveying, blending, and dosing of premium bulk solids. Thanks to our world-wide activities and locations in all important industrial centers we can always provide our clients with the latest, most innovative and reliable technology to ensure maximum economic success.

As the direct successor of Count Ferdinand von Zeppelin who turned the human dream of flying into reality by building his legendary airships over a century ago, we are used to looking ahead. Constantly innovating, striving for perfection and maximum functionality in our products has turned us into the company that Zeppelin is known as today: the technology leader for handling premium bulk solids.



On site world-wide – always near our customers. Production plants in Germany, Belgium, Brazil and Saudi Arabia, production partners in Thailand and China as well as subsidiaries and representations all over the world enable Zeppelin to serve its customers with speed, flexibility and the utmost closeness to them. More than 200 engineers – including specialists in chemical engineering – guarantee innovative and economic construction of plants.





Zeppelin has been the leader in the international market of silo construction for decades. Thanks to our own modern manufacturing and the international experience of our assembly staff and service engineers we guarantee quality of the highest level.

Competence in bulk solids handling – you can rely on Zeppelin

The industrial Zeppelin Group and its various divisions are focused on the requirements of their customer groups. All activities have, however, one thing in common: the economic handling of premium bulk solids.

Silo plants for the plastic, food, and chemical industries integrated in one logistics concept: from consultation and design to manufacture, assembly and after-sales service.

Turn-key plants for the plastics processing and chemical industry as well as for rubber producers and tiremakers.

Conveying components for any application: for powders or pellets, for high or low pressures, for products with good or poor flowability, for standard or special applications.

Silogistic: turn-key plants for plastics producers, engineering companies and forwarders. Zeppelin is the world-wide leader in the planning and construction of logistic centers and manufacturing plants.



Pulling all the strings: the central office for the industry sector is located in Friedrichshafen, Germany. Here, in the world's largest Technology Center for pellets and powders, tests are carried out on an industrial scale. The test results are available to all subsidiaries, therefore allowing our clients to always be on the safe side – no matter where their plant is located.





Plants for the plastics processing industry: benefit from the trends we are setting

Zeppelin is the leader in the international market for turn-key plants designed for the handling of high-quality bulk solids. Zeppelin's division for processor plants has specialized in high performance logistics for bulk plastic materials required by plastics processors.

Long-term experience, a reference list showing all important and renowned enterprises in the plastic industry as well as a variety of patented processes reveal the success of our technologies.

Zeppelin is the technology leader especially for processing plants for PVC, compounding plants or, among others, plants for the manufacturing of cross-linkable polyethylene cables by the cable industry. A world-wide network providing project management capacities on six continents and production plants in the most important economic regions ensure both continuous personal consultation and local assistance as well as the reliability of a partner with world-wide activities.

Our main focus is the economical operation of your plant. An exact quantity and compound of the raw material (pellets, powder, recycled material, or other bulk solids) must be filled into the production process in specified conditions and at the right moment. Zeppelin's technology stands for achieving the highest quality of your products with safe and reliable plant equipment.

Systems for economical raw material management



Plastic pellets are supplied in various packing forms. In order to take advantage of all opportunities the market offers already at the purchasing stage, the raw materials have to be processed quickly – whatever the form of packing – and sufficient storage capacities must be available.

In times of constantly increasing production outputs, product types and quality requirements, optimization can only be reached through coherent general concepts. Zeppelin has therefore developed economic, field-proven and reliable concepts especially for the plastics processing industry.

In order to be successful in the international markets one must take advantage of every opportunity, starting with purchasing raw materials. This means that your raw material may be supplied in different packing types. The only possibility to benefit from any advantages already at the purchasing stage is sufficient storage capacity and a system designed with flexibility in mind.

Whether you purchase your raw materials from the Vendor Management Inventory (VMI) or on free markets – for processing significant quantities of raw materials daily, you will require a flexible and reliable raw material management system. From receiving and testing bulk material via storage to just-in-time feeding from day-bins in the production – Zeppelin supplies material handling systems designed to fit your individual requirements.

Receipt of the product

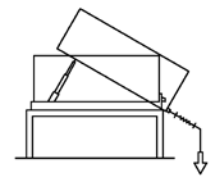

Container



Bulk storage bin

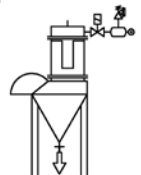

Bag emptying station

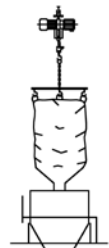

Big Bag

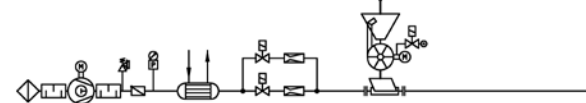

Blower station

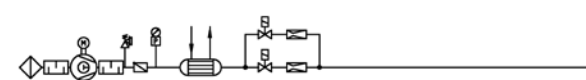

Modern engineering concepts position the raw materials as close as possible to the machines. For conveying the product from external silos to the day-bins in the production plant, Zeppelin uses technologies which are both highly efficient and product-gentle. The day-bins are therefore free of dust and streamers.



You can always rely on Zeppelin, the leader in silo technology. Turn-key silo plants, complete with accessories, smoothly integrated into your general logistics concept.



Complete discharge is ensured by the bag emptying station – available in a dust-free design with optional dust extraction for dust creating products.



Variable feeding: no matter the form of the raw material supplied (powder or pellets) – our intelligent turn-key systems offer the right solution for any task.



Storage

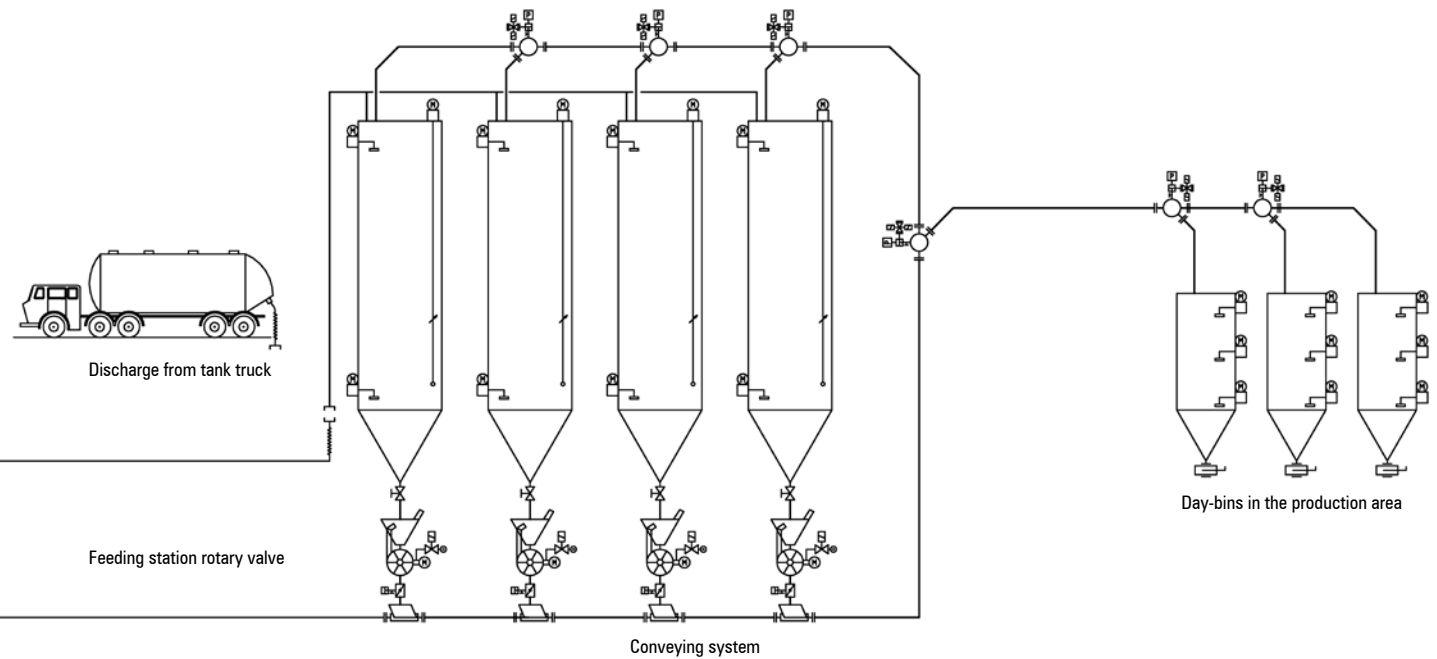

Material handling for plastic materials compounding



Because of the various raw materials which are hard to handle, the feeding system plays a significant role in compounding plastic materials. In this case as well is a complete system only as good as its individual components. Therefore, the chemical engineering adaptation and availability of the individual components are of significant importance for the economic efficiency of the entire process.

All steps of the process are designed to fit perfectly into the Zeppelin systems. The dosing systems as well as the extruders are of prime importance for your economic success. These must have maximum precision, high service quality and be reliable round-the-clock, as those of Zeppelin.

Zeppelin integrates the most suitable dosing systems as well as appropriate conveying systems in your plant for handling a wide range of raw materials and additives such as stabilizers, slip, softening, cross-linking and foaming agents, dyes, filling materials, flame retardants, glass or carbon fibers to increase the stability or mica to improve the appearance.

After the compounding procedure, the partly sensitive product must be smoothly transported and carefully packed. Cleaning and examination of the finished material by metallic collectors and elutriators as well as cleaning of the pipes, e.g. by pig systems, are important additions to the quality assurance program.

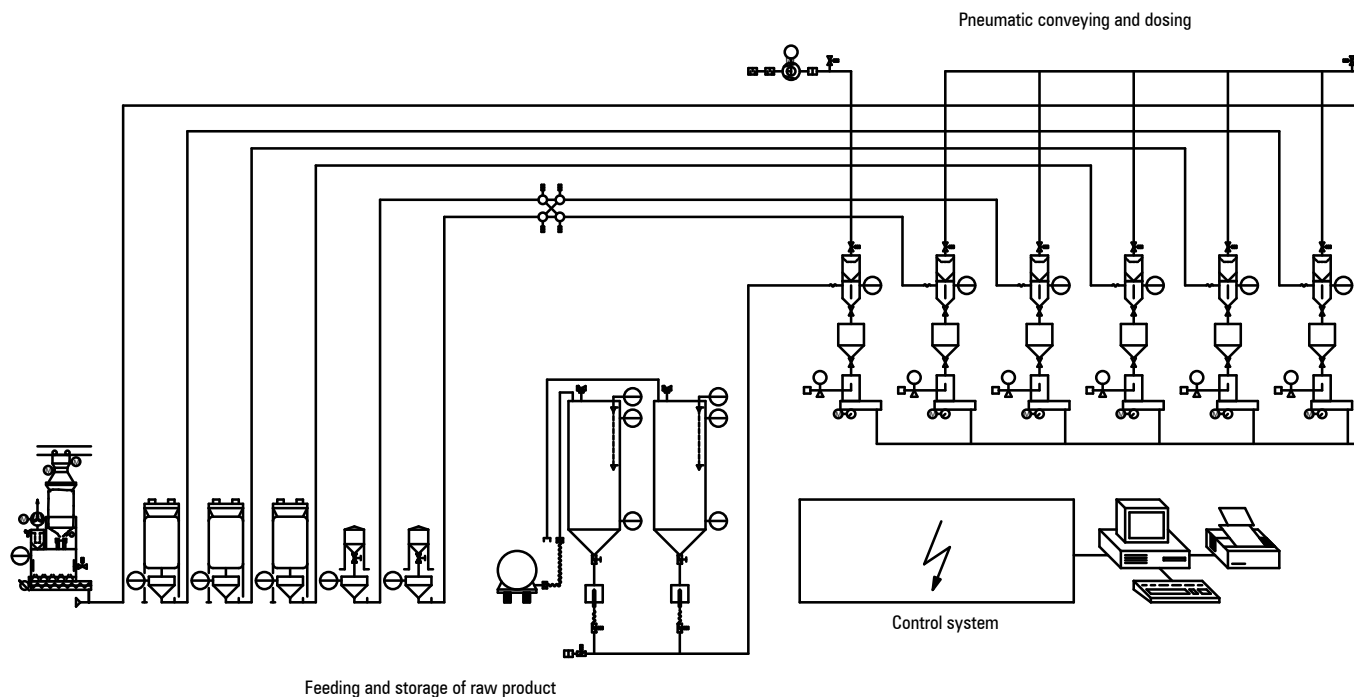

Special technologies such as Pump-Flow conveying ensure the reliable and trouble-free transport of glass fibers (image left) from the Big Bag or container to the dosing system. Thanks to gentle conveying, the product is undamaged and ready for trouble-free processing. (Image right: product destruction caused by wrong conveying method.)



Benefit from the know-how of the Zeppelin Group, throughout the industries. Being the market leader for raw material handling systems for the rubber and carbon black industry, we know difficult products very well and have developed special conveying technologies, such as Overflow. Gained experience which will also be considered in the design of your plant.



Co-extrusion plant for manufacturing industrial films. Here, Zeppelin ensures reliable dosing of the raw material in the manufacturing process with all necessary additives.



Dosing and mixing unit for granular products (DMG)

Feeding and dosing of minerals and glass fibers

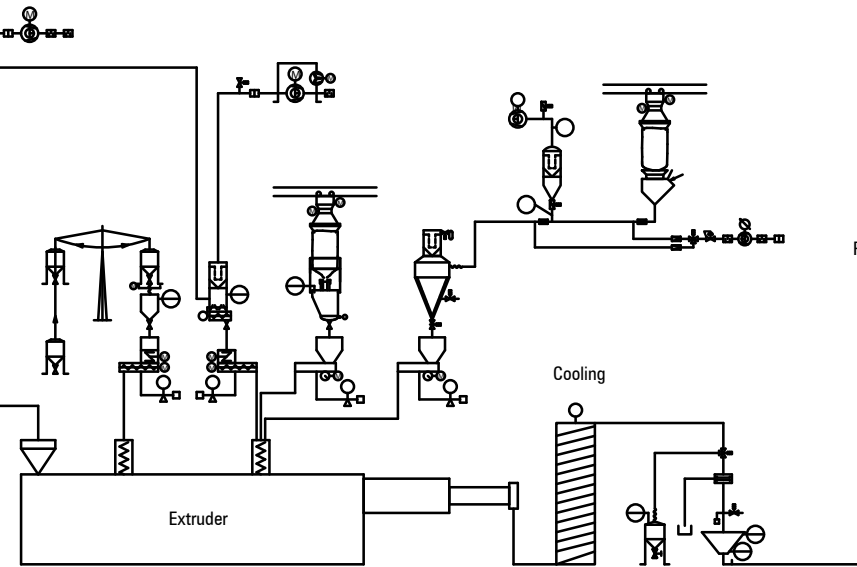

Discharge of off-spec material

Product-gentle conveying

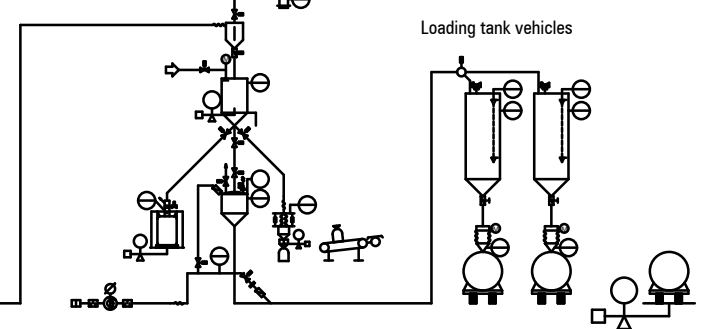

Packing in sacks, Big Bags, Octabins

Plants for the conditioning of PVC



Speaking of raw material costs: Minimizing waste is one of the conditions for competitive production. Off-spec materials, unspecified merchandise from spot markets, defective batches, waste from interruptions of production, faulty semi-finished goods, slugs or punching scrap are too expensive to be wasted. Therefore, Zeppelin provides special equipment and processes which assist you in optimizing this part of production as well.

The stability of the complete plant plays a crucial role in the treatment of PVC powder. When batch quantities are processed, the dosing systems must meet the highest requirements as to precision and reliability in order to guarantee consistently long-term high product quality.

The supply of a large variety of raw material requires a first-class administration of recipes, using a modern programmable controlling system. For frequent changes of recipes, rapid cleaning must be ensured. Because raw materials and additives' properties complicate the handling of bulk solids, they will be automatically dosed to heating/cooling mixer combinations according to their recipe.

After mixing the finished dryblend, it is conveyed to the extruder using buffer silos for intermediate storage – where the risk of product segregation can arise.

You can rely on the Zeppelin technology for these tasks as well: Depending on your application, pressure, suction or mechanical screw conveying will be selected – all gentle conveying methods which reduce the inevitable product segregation to a minimum. Inflatable conveying pipes, vibrated rubber or PE pipes and the Overflow bypass system ensure safe material handling even under the most difficult conditions. If required, blending silos which have been specially designed to overcome segregation problems can be connected afterwards.

Example of a plant for the treatment of PVC with two integrated heating/cooling mixer combinations and central weighing station for light-weight constituents. Feeding from extruders or injection moulding machines is either done pneumatically or by screw.

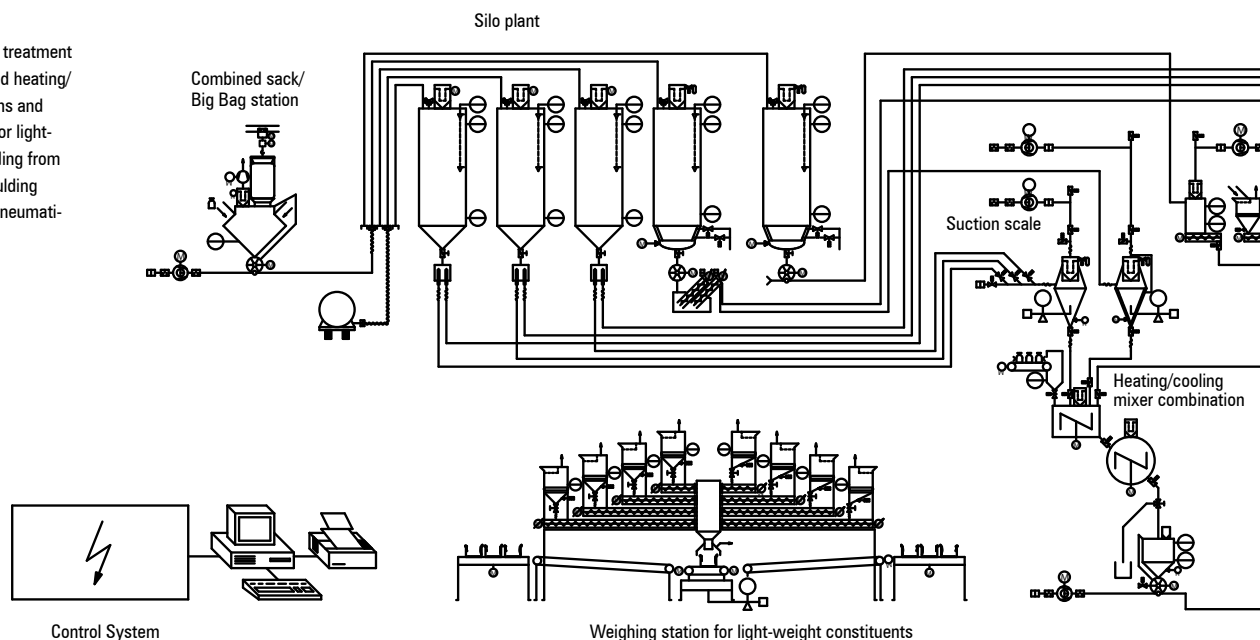

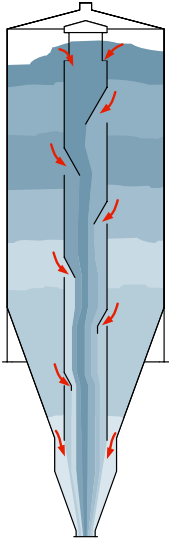

Zeppelin offers a large variety of blender types for homogenizing batch variations of PVC dryblends, blending and induction of rework material or blending granular compounds for homogenization of product variations.



Bag emptying system with flexible cone and feed screw for products with poor flowability



Scales for light-weight additives with flexible weighing hopper



Pellet cooler specially developed for the cable industry (PVC). Thanks to the optimum distribution of flow and limited residence times, it guarantees maximum cooling efficiency.



Hopper loader with integrated, fully automatic filter for PVC dryblends

Sack emptying / Big Bag stations

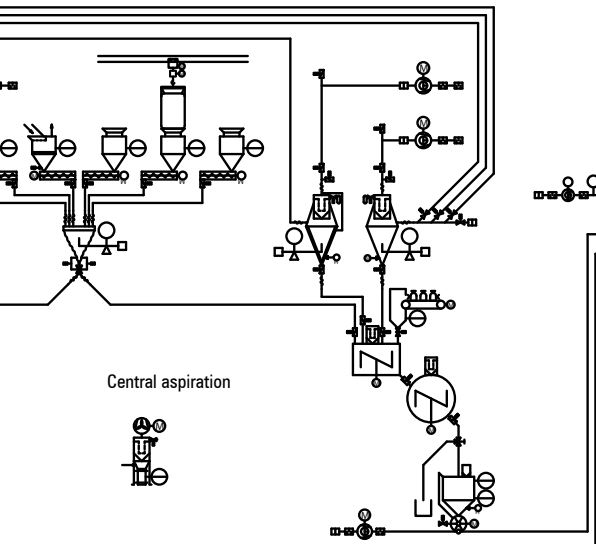

Intermediate storage of dryblend

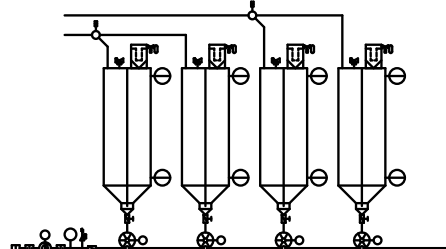

Transport to the extruder by screw conveyors

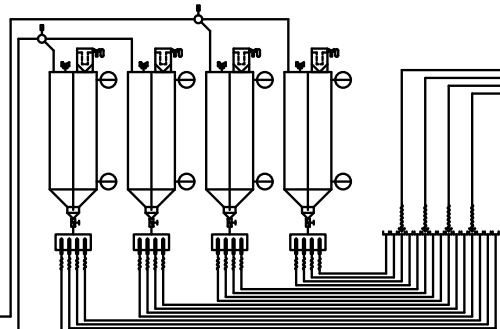
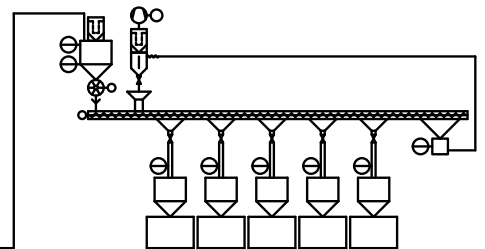

Transport to the extruder by a vacuum conveyor

The Zeppelin Pump-Flow-Concept®: economic and gentle conveying



Zeppelin introduces a patented plant concept for handling of bulk solids for the plastics processing industry. The Pump-Flow-Concept® combines both the flexibility of vacuum conveying with the efficiency of pressure conveying systems.

Several loading stations can be charged easily, quickly and economically by different feeding stations, thus reducing peripheral investments, the complexity of the plant and the operating expenses. The Pump-Flow-Concept® is also appropriate for retrofitting and ensures highest flexibility at long term. Best suitable for plants with a total consumption of 1.5 – 8 t/h.

Advantages of the Pump-Flow-Concept®:

- gentle conveying of bulk solids
- dust-free discharge from loading bins
- reduced overall height
- less space requirement
- low investment costs
- low wear
- highest flexibility
- simple control systems
- no air leakage
- universally applicable
- flexible construction
- expandable due to modular construction

Pump-Flow

patented concept®

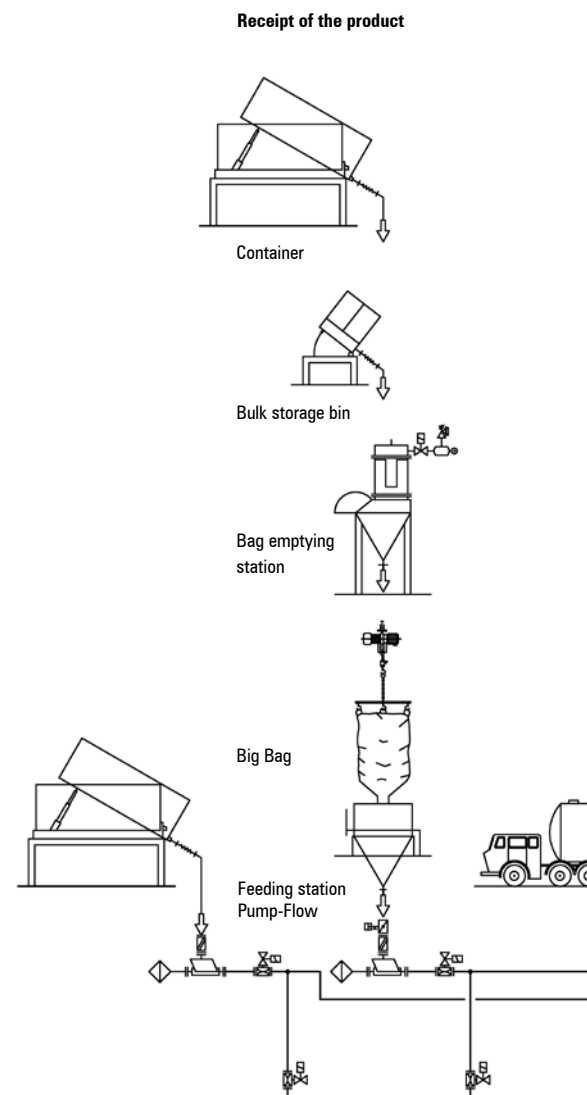



Demonstration plant in our Technology Center. Right: feeding of bulk solids from Big Bags. Left: Pump-Flow feeding station. Maximum conveying distance is 300 m, optionally dilute phase or dense phase conveying.

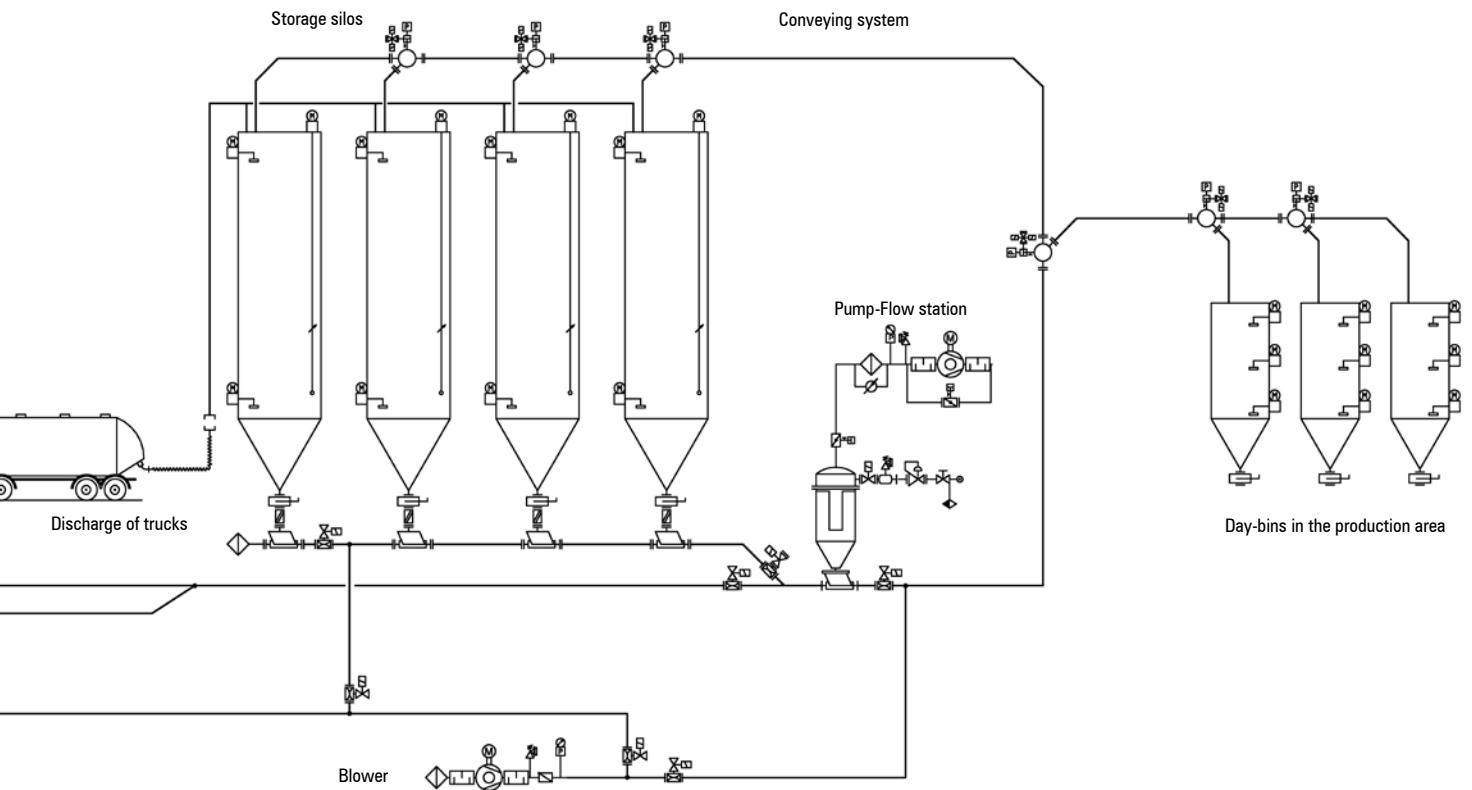

Material handling for manufacturing of medium and high voltage cables



Handling materials for the production of cable sheathings using VPE pellets is one of the most demanding tasks in bulk solids technology. The requirements for product purity are particularly high. Experience, know-how and perfectly adjusted complete systems determine the quality of the final product. That's precisely why you should trust in the market leader – and benefit from the experience gained through the realization of many other plants – for your success.

When insulating medium and high voltage cables, even the smallest impurities can cause significant damage. Therefore, handling raw materials in clean room conditions is the precondition for a reliable process.

Schematic showing material feeding at a production plant for medium and high voltage cables. In order to comply with the particularly high requirements of this process, specially designed fittings and gaskets as well as polished vessels with treated surfaces are used.

From the container unloading station with gentle product conveying, the feeding station, the buffer vessel, the dosing channel, the magnetic separator, the cascade separator to the buffer vessel for the extruder and to the filters – all components are specially designed for this application.

Avoiding peroxide clusters and impurities is the basis for a successful process. Therefore, we rely exclusively on our own knowledge for this task – all components have been exclusively designed by Zeppelin.

For this special application constructions without any dead zones have been developed. Shock-free pipe connections, special fittings, and gentle low-velocity conveying – here every detail is decisive.

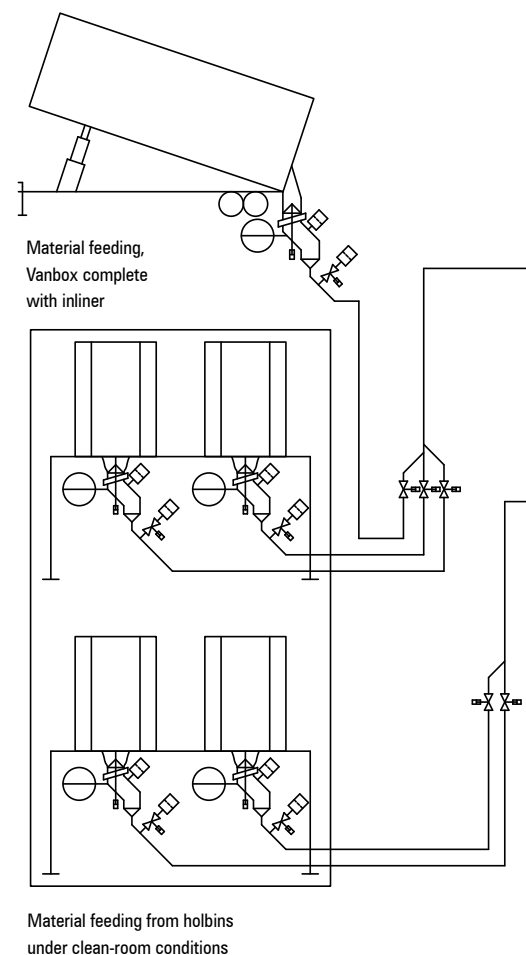



Cross section of a 110 kV cable. Cable sheathing made from cross-linkable plastic material (VPE). The cable sheathing is manufactured by a co-extruder (cross-section in full scale shown left).



Cascade separator with integrated metal separator and ionizer. Thanks to the special design, fine dust and impurities adhering to the pellet surface are separated from the raw material. One of the basic elements for avoiding impurities in a reliable way.

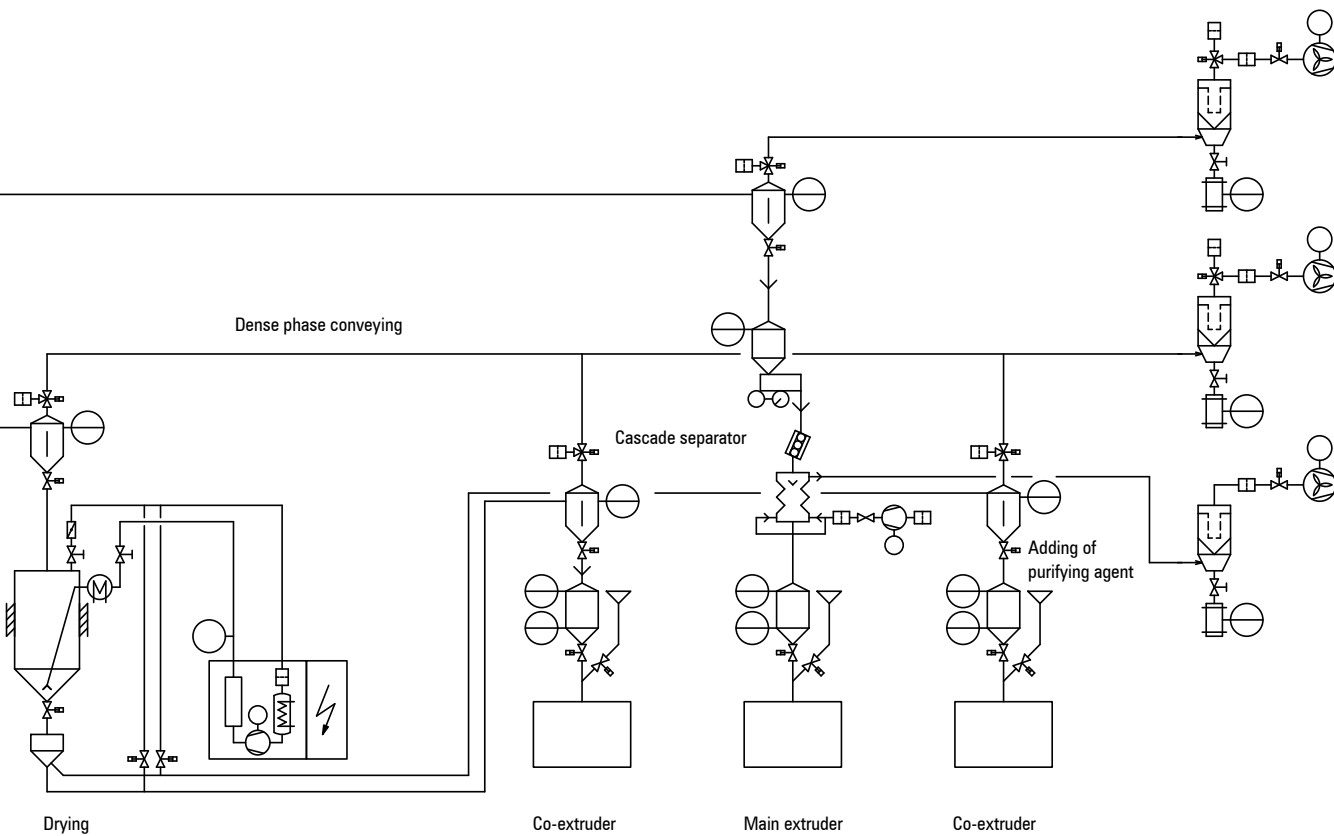

A comprehensive range of accessories for maximum customer value



Applications for material handling in connection with processing and conditioning of plastic materials require special know-how and specific products. Being a system supplier, Zeppelin offers a wide range of accessories in order to ensure the reliable and trouble-free realization of your processes. Some examples taken from our product range:

The experience gained through the realization of numerous plants is integrated in your plant's design. We know your requirements and offer you innovative solutions for any demand in economical, reliable and safe bulk material handling.

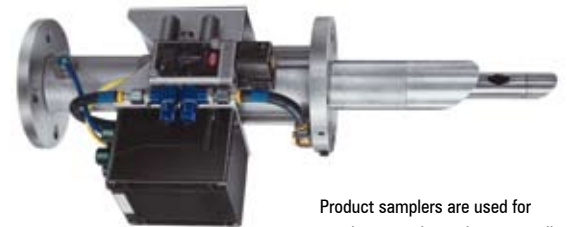

Product samplers are used for continuous or intermittent sampling in pneumatic conveying pipelines.

When discharging some products (e.g. PET, PA, TiO₂ and partly also PVC) from silos, vibrations or even honking may occur, a noise reaching up to 110 dbA. In order to avoid problems with noise emission

regulations or even with the steel structures, Zeppelin may install a patented anti-honking systems (shown bottom right): a so-called shear zone created near the silo wall inhibits the honking.

The Turbo Pig designed by Zeppelin is used for the perfect dry cleaning of conveying systems for powders and pellets. Because of its modular design, the Turbo Pig is suitable for various product and piping

requirements. Accidental mixing of products following a batch change can therefore be prevented.

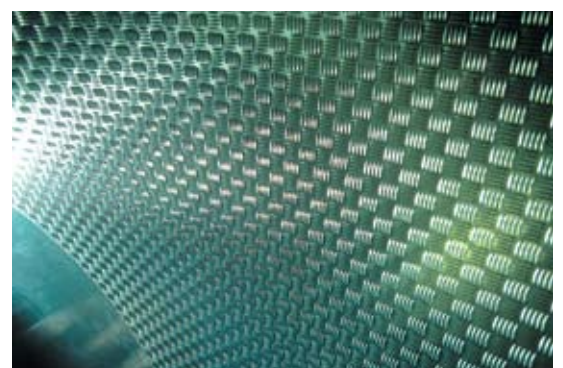
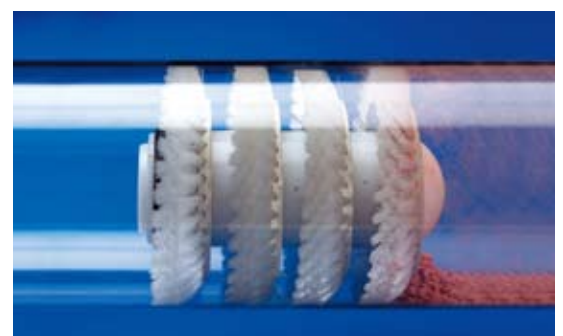

The Zeppelin streamer separator: specially developed for removing streamers without interruption of conveying for plants with an output of 3 – 30 t/h. (Image right: rotary cylinder of the streamer separator)



A particularly clever feature of Zeppelin's new program of diverter valves: the modular system allows individual adjustment of the diverter valve to your special requirements.



The weighing scale: perfectly suited for light-weight constituents. Fast, maintenance-free, easy cleaning. Also appropriate for adhesive products.



Universal vacuum hopper loader for automatic charging of extruders, processing machines, vessels, and storage silos for powders and pellets with an output of 100 kg/h to 2,000 kg/h. Low-maintenance thanks to large filter surfaces with jet cleaning. For use as individual unit or in multiple feeding systems.



Filter for use with scales or receiving hoppers





Leading-edge technology is no luck, it's an achievement

Your investments in individual components and complete systems must be profitable, using the right product for a specific job, readily available and at a fair price. Zeppelin, as the technology leader, runs a powerful Development and Technology Center researching different technologies for handling bulk solids.

To further contribute to your success we offer the services of our Technology Center whose capabilities span the entire Zeppelin product range. Acquiring factual information on your product helps you to select the best possible component or plant design.

Our Technology Center is built on an industrial scale to meet our customers' wide range of demands. For this reason we can provide you with tailored answers to your individual tasks, with trials on an industrial



Powders or pellets – we have all the answers

The heart of our research and development activities are the two Technology Centers – one specially designed for pellets and the requirements of the large scale chemical industry and the other for powders and additives (for the rubber and plastics processing industry).

Whether commercial-size installation or processing plant, we conduct full scale tests to avoid the uncertainties of scale-up calculations with the help of the Technology Center's impressive range of options. Because our customers naturally expect maximum process reliability, Zeppelin provides them with unquestionable results as a solid basis for their investment decisions.

To ensure the completeness and accuracy of the results, Zeppelin provides:

- competent result analysis by its specialists
- conclusive test reports and documentation
- determination of relevant design parameters



The Zeppelin Group of companies: All specialists under one roof

Zeppelin Silos & Systems GmbH

Leutholdstr. 108
88045 Friedrichshafen
Germany
E-mail: zentral.fn@zeppelin.com

Zeppelin Belgium N.V.

Munsterenstraat 9
3600 Genk
Belgium
E-mail: zeppelin.belgium@zeppelin.be

Zeppelin Technology Far East Pte, Ltd.

237 Alexandra Road
#03-03/04/05 The Alexcier
Singapore 159929
Singapore
E-mail: info@zeppelin.sg

Zeppelin Systems USA, Inc.

11050 West Little York
Building D
Houston, TX 77041
USA
E-mail: zeppelin-usa@zeppelin-usa.com

JMB Zeppelin Equipamentos Industriais Ltda.

Rua João XXIII, N° 650
Bairro Cooperativa
CEP 09851-707
São Bernardo do Campo
São Paulo
Brazil
E-mail: info@jmbz.com.br

Zeppelin Systems India Pvt. Ltd.

Level 4 – ADM-Building
Alembic Campus
Alembic Road
Vadodara - 390003
India
E-mail: info@zeppelin-india.com

Zeppelin Solid Technology (Beijing) Co. Ltd.

111#, Parkview Center
No. 5, Fangyuan West Road
Chaoyang District
Beijing 10016
China
E-mail: office@zeppelin-china.com

Zeppelin Plast Tech S.r.l.

Centro Direzionale „Summit“
Palazzo „C“/Via Brescia, 26
20063 Cernusco sul Naviglio (MI)
Italy
E-mail: info@zeppelin-zi.com

Zeppelin Systems Ltd.

Multiflex 5, Core 27
Little Oak Drive
Sherwood Business Park
Annesley
Nottingham NG15 0EB
United Kingdom
E-mail: info@zeppelin-uk.com

Zeppelin Representative Office Moscow

Leninskij Prospekt 95 A, Room 464
119313 Moscow
Russia
E-mail: marcus.reichmann@zeppelin.com

Zeppelin Gulf Company Ltd.

Dammam-Jubail Highway
Juaymah
P.O. Box 9998, Dammam 31423
Kingdom of Saudi Arabia
E-mail: zeppelingulf@zeppelin-gulf.com

Zeppelin Silo ve Sistemleri Imalat Sanayi Ticaret A.S.

F. Kerim Gökyay Cad.
Ortabahar Sok. No. 6/32
34732 Göztepe – Istanbul
Turkey
E-mail: mehmet.tuerker@zeppelin-tr.com



Presented by:

Please visit our web site:
<http://www.zeppelin-industry.com>
© Zeppelin Silos & Systems GmbH,
SD 02/09. Subject to modifications
without notice. (Turn-key plants for
the plastics processing industry)